

## MOTORIZED ROLLER WORKSHEET

Company: \_\_\_\_\_ Date: \_\_\_\_\_  
 Contact: \_\_\_\_\_ Quote Due: \_\_\_\_\_ Desired Delivery: \_\_\_\_\_  
 Phone No.: \_\_\_\_\_ Contact Email: \_\_\_\_\_  
 NorthAmCon, Inc. Sales Contact: \_\_\_\_\_ Quote #: \_\_\_\_\_  
 Part # of Rollers Currently Used: \_\_\_\_\_  
 Brand Preference: \_\_\_\_\_

### Roller Specifications

Roller Quantity: \_\_\_\_\_  
 Roller Size:  1.9 OD x 7/16" Hex  
                    2.5 OD x 11/16" Hex  
 Between Frame (inches) - A: \_\_\_\_\_  
 Tube Length (inches) - B: \_\_\_\_\_  
 Groove/Sprocket Location (inches) - C: \_\_\_\_\_  
 Groove/Sprocket Location (inches) - D: \_\_\_\_\_  
 Plain  
 Grooved  
 Poly Ribbed  
 Sprocketed  
 Retention  
 Spring Retained  
 Other

### Application Information

Desired Speed (FPM): \_\_\_\_\_  
 Maximum Weight (lbs): \_\_\_\_\_  
 Transported Material Type: \_\_\_\_\_  
 Conveyor Type: \_\_\_\_\_  
 Roller Center-to-Center (inches): \_\_\_\_\_  
 Idler Rollers (quantity): \_\_\_\_\_  
 Motor Lead (Cable) Length (inches): \_\_\_\_\_

### Driver Cards

Card (qty) \_\_\_\_\_  
 Card Functions Required: \_\_\_\_\_  
 Transportation  
 Zero Pressure  
 Special Interface: \_\_\_\_\_

### Brief Application Description

(include extreme environmental and operating conditions, i.e. wet, oily, washdown, cold, hot, etc.): \_\_\_\_\_

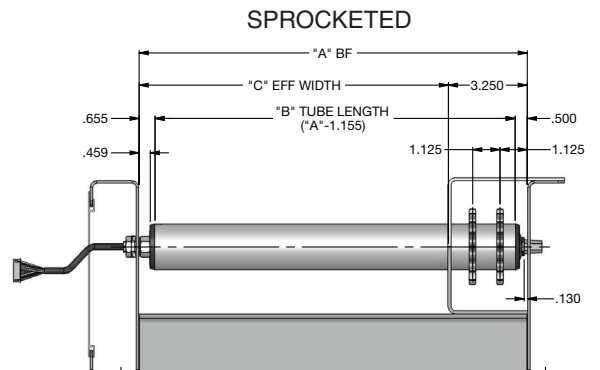
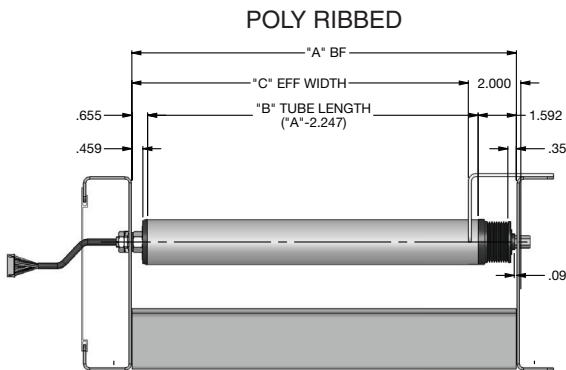
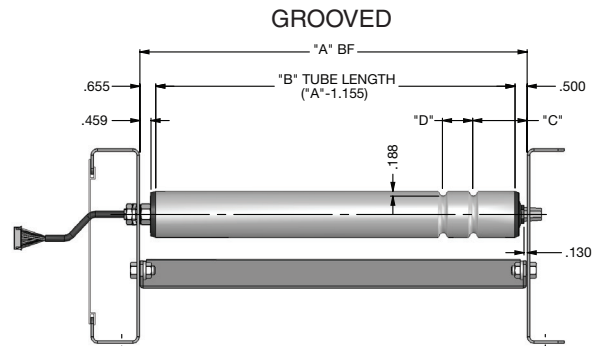
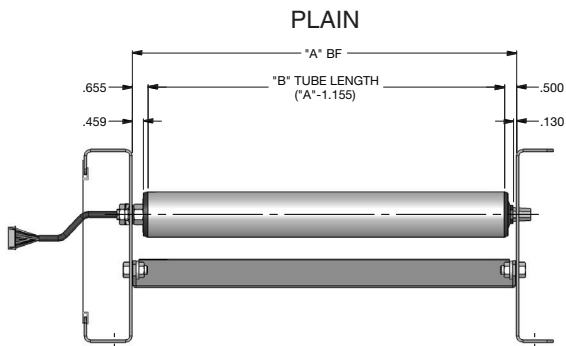

Proposal Drawing Required:  Yes  No