

FLAT MOTOR CONVEYOR WORKSHEET

Company _____ Date _____
 Contact _____ Quote Due _____ Desired Delivery _____
 Phone No. _____ Contact Email _____ State _____
 NorthAmCon, Inc. Sales Contact _____ Quote #: _____
 Quantity _____

Product Specs:

Max:
 - Width (inches): _____ Length (inches): _____
 - Height (inches): _____ Weight (lbs): _____
Min:
 - Width (inches): _____ Length (inches): _____
 - Height (inches): _____ Weight (lbs): _____
 Description: _____
 Max. Qty.: _____ Total Live Load: _____
 Temperature
 -Environment: _____
 -Product: _____

Roller Specs:

1.9 in. dia. x 16 ga. Galv. Other: _____
 Coating: _____

Support Type:

Quantity: _____
 Legs Ceiling Supports TOR ___ +/- _____

Application Type:

Transportation
 Zero Pressure - Zone Length _____

Conveyor Construction:

Between Frame (BF) _____
 Roller C/C _____
 Roller Height: 1/4" high 1-3/4" low
 Straight Length: _____
 Curve - Degree: _____
 Inside Radius (I.R.): _____
 Bolt-Together
 Galvanized Painted Powder Coat
 Color/RAL: _____
 Welded
 Gloss Black Powder Coat
 Color/RAL: _____
 Lexan Covers

Plant Voltage:

110V Single
 220V Single Phase
 460V Three Phase

Speed:

Fixed _____ FPM
 Variable _____ to _____ FPM

Controls:

Zone Photo Eye Yes No
 Entry Zone Photo Eye Yes No
 Power Distribution Cables Yes No
 Power Supply Yes No

Approval Drawing Required: Yes No

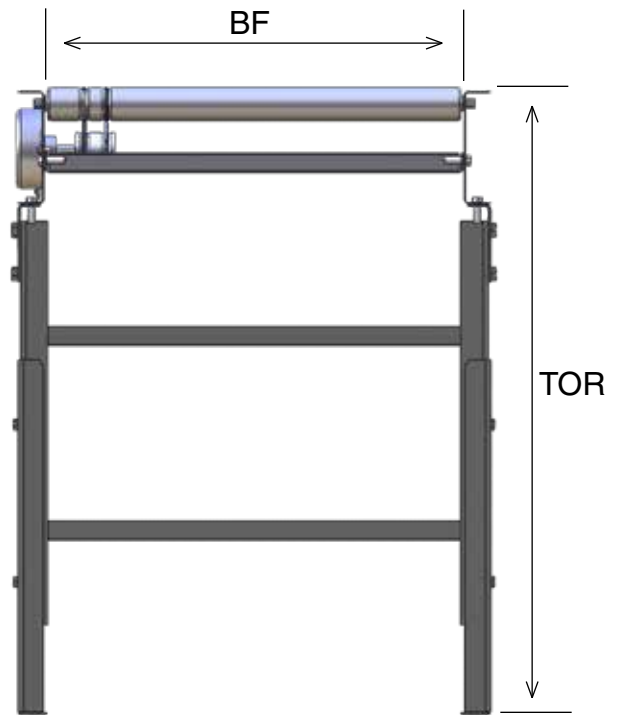

Notes: _____

